

# 1 Introduction

## *Tracing the Historical Development of Metalworking Fluids*

*Jeanie S. McCoy*

### CONTENTS

|         |  |    |
|---------|--|----|
| 1.1     | What Are They? .....   | 1  |
| 1.2     | Current Usage in the United States .....                                     | 2  |
| 1.3     | History of Lubricants: Evidence for Early Usage of Metalworking Fluids ..... | 2  |
| 1.4     | History of Technology .....  | 3  |
| 1.4.1   | Greek and Roman Era .....  | 3  |
| 1.4.2   | The Renaissance (1450–1600) .....  | 3  |
| 1.4.3   | Toward the Industrial Revolution (1600–1750) .....                           | 3  |
| 1.5     | Evolution of Machine Tools and Metalworking Fluids .....                     | 5  |
| 1.5.1   | Early Use of Metalworking Fluids in Machine Tools .....                      | 5  |
| 1.5.2   | Growth of Metalworking Fluid Usage .....                                     | 6  |
| 1.5.3   | After the Industrial Revolution (1850–1900) .....                            | 6  |
| 1.5.3.1 | Discovery of Petroleum in the United States .....                            | 7  |
| 1.5.3.2 | Introduction of Better Alloy Steels .....                                    | 8  |
| 1.5.3.3 | Growth of Industrial Chemistry .....   | 8  |
| 1.5.3.4 | Use of Electricity as a Power Source .....                                   | 8  |
| 1.5.4   | Early Experimentation with Metalworking Fluids .....                         | 8  |
| 1.5.5   | Status of Metalworking Fluids (1900–1950) .....                              | 10 |
| 1.5.5.1 | Development of Compounded Cutting Oils .....                                 | 10 |
| 1.5.5.2 | Development of Soluble Oils .....  | 11 |
| 1.5.5.3 | Influence of World War II .....  | 12 |
| 1.5.5.4 | Mechanisms of Cutting Fluid Action .....                                     | 12 |
| 1.5.5.5 | Metalworking Fluids and the Deformation Process .....                        | 13 |
| 1.6     | Metalworking Fluids Today .....  | 14 |
|         | References .....   | 15 |

### 1.1 WHAT ARE THEY?

Metalworking fluids are best defined by what they do. Metalworking fluids are engineering materials that optimize the metalworking process. Metalworking is commonly seen as two basic processes: metal deformation and metal removal or cutting. Comparatively recently, metal cutting has also been considered a plastic deformation process—albeit on a submicro scale and occurring just before chip fracture.

In the manufacturing and engineering communities, metalworking fluids used for metal removal are known as *cutting and grinding fluids*. Fluids used for the drawing, rolling, and stamping processes of metal deformation are known as *metalforming fluids*. However, the outcome of the two

processes differs. The processes by which the machines make the products, the mechanics of the operations, and the requirements for the fluids used in each process are different.

The mechanics of metalworking govern the requirements demanded of the metalworking fluid. As all tool engineers, metalworking fluid process engineers, and machinists know, the fluid must provide a layer of lubricant to act as a cushion between the workpiece and the tool in order to reduce friction. Fluids must also function as a coolant to reduce the heat produced during machining or forming. Otherwise, distortion of the workpiece and changed dimensions could result. Further, the fluid must prevent metal pickup on both the tool and the workpiece by flushing away the chips as they are produced. All of these attributes function to prevent wear on the tools and reduce energy requirements. In addition, the metalworking fluid is expected to produce the desired finish on an accurate piece-part. Any discussion of metalworking fluid requirements must include the fact that the manufacturing impetus since the days of the Industrial Revolution has been to machine or form parts at the highest rate of speed with maximum tool life, minimum downtime, and the fewest possible part rejects (scrap), all while maintaining accuracy and finish requirements.

## 1.2 CURRENT USAGE IN THE UNITED STATES

The number of gallons of metalworking fluids produced and sold in the United States represents a significant slice of the gross national product, as indicated in a 2013 report. Of the 2400 million gallons of total lubricant demand in the United States, 141 million gallons were metalworking fluids.<sup>1</sup>

Kline & Company reported the global annual demand for metalworking fluids in 2012 was 2.2 million tons, or approximately 525 million gallons (1.987 billion liters), worldwide. Of this amount, 49% were for metal removal, 30% for forming, 12% for metal protection, and 9% for metal treating. The largest demand (42%) was in Asia, 28% in North America, 26% in Europe, and 4% in the rest of the world.<sup>2</sup>

These statistics indicate the importance and wide usage of metalworking fluids in the manufacturing world. How they are compounded, used, and managed and how they impact health, safety, and environmental considerations will be described in subsequent chapters. This chapter will take the reader through the history of the evolution of metalworking fluids, one of the most important and least understood tools of the manufacturing process.

It is surprising that it is not possible to find listings for metalworking fluids in the available databases. The National Technology Information Service, the Dialog Information Service, the well-known Science Index, the Encyclopedia of Science and Technology Index, and the *Materials Science Encyclopedia* all lack relevant citations. The real story appears to be buried in technical magazines written by engineers and various specialists for other engineers and specialists, and is obscured in books on related topics. Clearly, this is an indication that this information needs to be collected and published.

## 1.3 HISTORY OF LUBRICANTS: EVIDENCE FOR EARLY USAGE OF METALWORKING FLUIDS

The histories of Herodotus and Pliny, and even the scriptures, indicate that humankind has used oils and greases for many applications. These include lubrication uses such as hubs on wheels, axles, and bearings, as well as nonlubrication uses such as embalming fluids, illumination, the waterproofing of ships, the setting of tiles, unguents, and medicines.<sup>3</sup> However, records documenting the use of lubricants as metalworking fluids are not readily available. Histories commonly report that man first fashioned weapons, ornaments, and jewelry by cold working the metal; then, as the ancient art of the blacksmith developed, by hot working the metal. Records show that animal and vegetable oils were used by early civilizations in various lubrication applications. Unfortunately, the use of

lubricants as metalworking fluids in the metalworking crafts is not described in those early historical writings.<sup>4</sup>

Reviewing the artifacts and weaponry of the early civilizations of Mesopotamia, Egypt, and later the Greek and Roman eras on through the Middle Ages, it is obvious that forging and then wire drawing were the oldest of metalworking processes.<sup>5</sup> Lubricants must have been used to ease the wire-drawing process. Since metalworking fluids are, and always have been, an important part of the process, it may not be unreasonable to presume that the fluids used then were those that were readily available. These included animal oils and fats (primarily whale, tallow, and lard), as well as vegetable oils from various sources such as olive, palm, castor, and other seed oils.<sup>6</sup> Even today, these are used in certain metalworking fluid formulations. Some of the most effective known lubricants have been provided by nature. Only by inference, since records of their early use have not been found, can we speculate that these lubricants must have been used as metalworking fluids in the earliest metalworking processes.

## 1.4 HISTORY OF TECHNOLOGY

### 1.4.1 GREEK AND ROMAN ERA

The explanation for the lack of early historical documentation might be found by examining the writings of the ancient Greek and Roman philosophers on natural science. It is readily seen that there was little interest among the “intelligentsia” for the scientific foundations of the technology of the era.

As Singer points out in his *History of Technology*, the craftsman of that era was relegated to a position of social inferiority because knowledge of the technology involved in the craft process was scorned as unscientific. It was neither studied nor documented, evidently not considered as being worthy of preservation.<sup>7</sup> Consequently, the skills and experience of the craftsman became valuable personal possessions to be protected by secrecy; the only surviving knowledge was handed down through the generations.<sup>8</sup>

### 1.4.2 THE RENAISSANCE (1450–1600)

During the Renaissance, plain bearings of iron, steel, brass, and bronze were increasingly used, especially da Vinci's roller disk bearings in clock and milling machinery as early as 1494; Agricola confirmed the wide use of conventional roller bearings in these applications.<sup>9</sup> Although machines were developed to make these parts, there is no record that any type of metalworking lubricant was used in bearing, gear, screw, or shaft manufacture. It is possible that those parts that were made of soft metals such as copper and brass did not require much, if any, lubrication in the manufacturing process, but it would seem logical that the finish requirements of iron and steel parts would demand the use of some type of metalworking fluid.

John Schey, in his book *Metal Deformation Processes*, points out that metalworking is probably humankind's first technical endeavor and, considering the importance of the lubricants used in the process, he was amazed to find no record of their use until fairly recent times.<sup>10</sup>

### 1.4.3 TOWARD THE INDUSTRIAL REVOLUTION (1600–1750)

It was shortly after the turn of the seventeenth century that scientific inquiry into the mechanics of friction and wear became the seed that promoted an appreciation for the value of lubrication for moving parts and metalworking processes. The first scant references to lubrication were in the descriptions of power-driven machinery (animal, wind, and water) by early experimenters on the nature of friction.

In China, Sung Ying-Hsing (1637) wrote of the advantage of oil in cart axles. Hooke (1685) cautioned on the need for adequate lubrication for carriage bearings, and Amontons (1699) elucidated the laws of friction in machines through experimentation. In the same year (1699), De la Hire described the practice of using lard oil in machinery. Desaugliers (1734) suggested that the role of the lubricant was to fill up the imperfections on surfaces and act as tiny rollers, and Leupold (1735) recommended that tallow or vegetable oil should be used for lubricating rough surfaces.<sup>11</sup>

It is interesting to note that although Amontons's endeavors are often considered to be experiments in dry friction, his notes carefully recorded the use of pork fat to coat the sliding surfaces of each experiment. As Dowson points out, Amontons was really studying the frictional characteristics of lubricated surfaces under conditions now depicted as boundary lubrication,<sup>12</sup> the mechanism operating most frequently in metalworking operations.<sup>13</sup> These concepts were basic to the development of theories of friction and wear during the eighteenth century, culminating in the profound works of Coulomb, who theorized that both adhesion and surface roughness caused friction.

In the nineteenth century, the means to mitigate friction and wear through lubrication were investigated, leading to the Reynolds theory of fluid film lubrication. In the early part of the twentieth century, Hardy with Doubleday introduced the concept of boundary lubrication, which to this day is still a cornerstone of our knowledge on the theory of lubrication.<sup>4</sup> It should be noted that William Hardy's works on colloidal chemistry paved the way for the development of *water-soluble* cutting fluids.

However, it was not the development of scientific theory that ultimately led to the explosion of research in this area, and especially on the mechanics of metalworking and metalworking fluids in the twentieth century. Rather, it was the wealth of mechanical inventions and evolving technologies that created the need to understand the nature of friction and wear, and how these effects can be mitigated by proper lubrication.

Interest in craft technologies soared during this period with the founding of the Royal Society of England in 1663 by a group identifying themselves as the "class of new men," interested in the application of science to technology.<sup>8</sup> Their most significant contribution was the sponsorship of *Histories of Nature, Art or Works*, which for the first time contained scientific descriptions of the craft technologies as practiced in the seventeenth century for popular use. Although the *Histories* published surveys on a wealth of subjects and long lists of inventions as described by Thomas Sprat, the only reference to a metalworking operation was in the treatise "An Instrument for Making Screws with Great Dispatch." No mention was made of metalworking fluid usage.<sup>14</sup>

The lack of early information on machining fluids can only be attributed to a reluctance on the part of the craftsman, seen even today on the part of manufacturers, to disclose certain aspects regarding the compounding of the fluids. The revelation of "trade secrets" that might yield a competitive advantage is not done unless the publicity for market value is seen to outweigh the consequence of competitors learning "how to do it."

Some information on lubrication in metal deformation processes, however, has been documented. K.B. Lewis relates that, in the seventeenth century, wire drawing was accomplished with grease or oil, but only if a soft, best quality iron was used. High friction probably caused steel wire to break.<sup>15</sup> Around 1650, Johann Gerdes accidentally discovered a method of surface preparation that permitted the easy drawing of steel wire. It was a process called *sull-coating*, whereby iron was steeped in urine until a soft coating developed. This procedure remained in practice for the next 150 years; later, diluted, sour beer was found to work as effectively. By about 1850, it was discovered that water worked just as well.<sup>16</sup> Although the process of rolling was applied to soft metals as early as the fifteenth century—and in the eighteenth century, wire rod was regularly rolled—lubricants were not, and are still not, used for rolling rounds and sections.<sup>17</sup>

Since research into the history of lubrication and the history of technology has not yielded documentation on the early use of metalworking fluids, consideration of the elements involved in the metalworking process led to a search through the history of machine tool evolution for answers. A few surprising facts came to light.

## 1.5 EVOLUTION OF MACHINE TOOLS AND METALWORKING FLUIDS

L.T.C. Rolt, writing on the history of machine tools, states unequivocally that through all the ages, the rate of man's progress has been determined by his tools. Indeed, the pace of the Industrial Revolution was governed by the development of machine tools.<sup>18</sup> This statement is echoed by R.S. Woodbury, who points out that historians have traditionally described the political, social, and economic aspects of human endeavor; including the inventions concerned with power transmission, new materials (steel), transportation, and the textile industry. Most have overlooked the technological development of the machine tool, "without which the steam engines and other machinery could not have been built, and steels would have little significance."<sup>19</sup>

This same observation could be further extended to include the significance of the technological development of metalworking fluids, without which the machine tool industry could not have progressed to where it is today. The development of metalworking fluids was the catalyst permitting the development of energy-efficient machine tools having the high speed and feed capacities required for today's production needs for extremely fast metalforming and metal cutting operations.

In general, machine tool historians seem to believe that the bow drill was the first mechanized tool, as seen in bas-reliefs and carvings in Egypt in approximately 2500 BC.<sup>20</sup> The lathe, probably developed from the mechanics of the potter's wheel, can be seen in paintings and woodcuts as early as 1200 BC.<sup>21</sup> In the Greek and Roman era (first century BC and the first century AD) the writings of three authors on technical processes describing various mechanisms have survived.

Hero of Alexandria (50 to 120 A.D.) whose works include mechanical subjects.

Frontinus (Sextus Julius, 35 B.C. to 37 A.D.) who concentrated on water engineering mechanisms.

Vitruvius, whose ten books, *De architectura* (31 B.C.) were the only "work of its kind to survive from the Roman world." Book VIII, devoted to water supplies and water engineering, refers to the use of a metalworking fluid. Vitruvius describes a water pump with a bronze piston and cylinders that were machined on a lathe with *oleo subtracti*, indicating the use of olive oil to precision turn the castings.<sup>22</sup>

The first record of a mechanized grinding operation that was accomplished by use of a grinding wheel for sharpening and polishing is evidenced in the Utrecht Psalter of 850 AD, which depicted a grinding wheel operated by manpower turning a crank mechanism.<sup>23</sup> The first grinding fluid was probably water, used as the basic metal removal process in the familiar act of sharpening a knife on a whetstone, as is still done today.

### 1.5.1 EARLY USE OF METALWORKING FLUIDS IN MACHINE TOOLS

Undoubtedly, water was used as the cutting fluid as grinding machines became more prevalent. Evidence for this presumption is seen in a 1575 copper engraving of a grinding mill by Johannes Stradanus that is similar to drawings by Leonardo da Vinci. The engraving depicts a shop set up to grind and polish armor, where "the only addition appears to be chutes to supply water to some of the wheels."<sup>24</sup>

It was common practice in Leonardo's day to use tallow on grinding wheels. An indication that oil was also used as a metalworking fluid is illustrated in Leonardo's design for an internal grinding machine (the first hint of a precision machine tool), which had grooves cut into the face of the grinding wheel to permit a mixture of oil and emery to reach the whole grinding surface.<sup>25</sup>

The development of machine tools was slow during the following 200 years. In this period, the manufacturing of textiles flourished in England with the invention of Hargreaves's spinning jenny and Arkwright's weaving machinery. Carton Ironworks was founded in 1760, no doubt resulting in the improvement of iron smelting and steel making. These inventions, plus the introduction of cast iron shafts in machinery, all gave impetus to design machine tools in order to produce these new kinds of machine parts. Still, by 1775, the available machine tools for industry had barely advanced beyond those that were used in the Middle Ages.<sup>26</sup>

The troubles between England and the colonies that began in 1718 resulted in a series of events that in time actually promoted machine tool development and the use of metalworking fluids. At that time, American colonial pig iron was exported to England. This alarmed the British ironmasters because they considered the colonies a good market for their iron production. They were successful in banning the importation of American manufactured iron. In addition, in 1750, the government of England prohibited the erection of steel furnaces, plating forges, and rolling mills in the colonies. In 1785, Britain passed laws that prohibited the exportation of tools, machines, engines, or persons connected with the iron industry or the trades evolving from it to the newly formed United States.<sup>27</sup> The rationale for this edict was to impact the economy of the colonies by hindering the developing American manufacturing industries and forcing the colonies to purchase English-manufactured items. Rather than impeding this American technical development, the British ban stimulated the ingenuity of the American manufacturing pioneers to develop tools, machines, and superior manufacturing skills.

These events encouraged the development of the American textile industry. It was quickened by the inventions of Eli Whitney, first with his cotton gin, permitting the use of very “seedy” domestic cotton, followed by his unique system of rifle manufacturing. The munitions industry began to flourish in America. Whitney developed the system of “interchangeable parts,” made possible by the more precise machining of castings, by which parts of duplicate dimension were effected through measurement with standard gauges. Whitney has been called the father of mass production, in that he dedicated each machine to a specific machining operation, and then assembled rifles from baskets of parts holding the product of each machine.<sup>28</sup> This system of manufacture was quickly adopted by other American and European manufacturers. Whitney continued to be a forerunner of machine tool invention in order to keep pace with the new manufacturing demand. He is credited with the invention of the first milling machine, a multipoint tool of great value.<sup>29</sup> However, there is no mention of any metalworking fluid used in any of the machining processes—probably known only to the machinist as one of the skills of his trade.

### 1.5.2 GROWTH OF METALWORKING FLUID USAGE

The practice of using metalworking fluids was concomitant with machine tool development both in the United States and in England. R.S. Woodbury relates further evidence for the use of water as a metalworking fluid. In 1838, James Whitelaw developed a cylindrical grinding machine for grinding the surface of pulleys, wherein “a cover was provided to keep in the splash of water.”<sup>30</sup> James H. Nasmyth, in his 1830 autobiography, describes the need for a small tank to supply water, or soap and water, to the cutter to keep it cool. This consisted of a simple arrangement of a can to hold the coolant supply and an adjustable pipe to permit the coolant to drip directly onto the cutter.<sup>31</sup>

Woodbury relates that the more common practice of applying cutting fluid during wet grinding (using grinding lathes) was holding a wet sponge against the workpiece. That practice was soon abandoned. A December 1866 drawing shows that a supply of water was provided through a nozzle, and an 1867 drawing shows a guard installed on the slideways of that same lathe to prevent the water and emery from corroding and pitting the slideways.<sup>30</sup> In retrospect, after reviewing the developments in machine tools and machine shop practice, it is obvious that the majority of modern machine tools had been invented by 1850.<sup>26</sup>

### 1.5.3 AFTER THE INDUSTRIAL REVOLUTION (1850–1900)

The next 50 years saw rapid growth in the machine tool industry and concurrently in the use of metalworking fluids. This came about as a result of the new inventions of this period, which in response to the great needs for transportation saw the development of nationwide railways. The next century saw the development of the automobile and aircraft. In order to build these machines, machine tools capable of producing large heavy steel parts were rapidly designed (Figure 1.1).

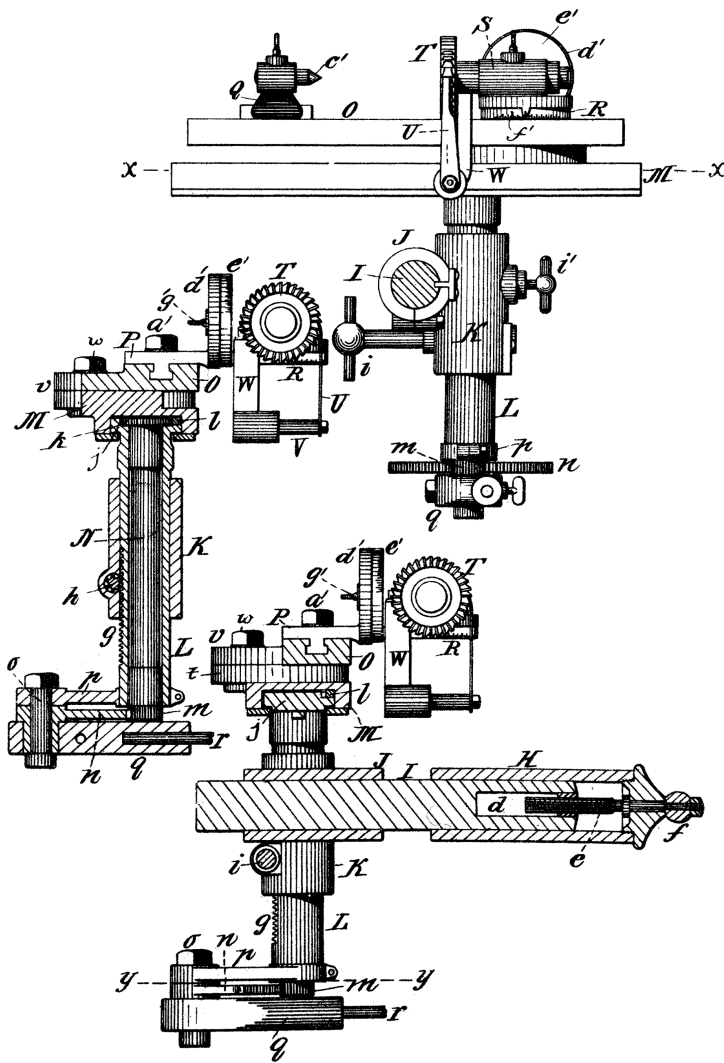

FIGURE 1.1 Diagram of cutter grinder developed by F. Holz, U.S. Patent No. 439,154 (1890).

In this period there was growing awareness of the value of metalworking fluids as a solution to many of the machining problems emerging from the new demands on the machine tools. However, there were four significant happenings that altogether made conditions ripe for rapid progress in the development of compounded metalworking fluids, which paralleled the sophistication of machine tools.

### 1.5.3.1 Discovery of Petroleum in the United States

One of the most important factors was the discovery of huge quantities of petroleum in the United States in 1859, which eventually had a profound influence on the compounding of metalworking fluids. Petroleum at that time was largely refined for the production of kerosene used for illumination and fuel. The aftermath of the Civil War with its depressed economic climate led refiners to find a use for oil, which was considered a by-product and had been discarded as useless. This caused an environmental problem for the city of Cleveland. The refiners, forced to find a solution to the oil “problem,” induced industry to use oil for lubricant applications, with the result that mineral oils then began to replace some of the popular animal and vegetable oil-based lubricants.<sup>32</sup> During

this period, some of today's famous independent lubricant manufacturing companies came into existence, offering a variety of compounded lubricants and cutting oils to improve the machining process and permit greater machine output. Some of these original specialty lubricant manufacturers have since been absorbed into the prevailing industrial conglomerates.<sup>33</sup>

### 1.5.3.2 Introduction of Better Alloy Steels

The second factor influencing the development of metalworking fluids was the development of alloy steels for making tools. David Mushet, a Scotch metallurgist, developed methods of alloying iron to make superior irons. One of his sons, Robert Forest Mushet, also a metallurgist, founded a method of making Bessemer's pneumatic furnace produce acceptable steels. Some writers claim that Bessemer's furnace was predated by 7 years by the "air-boiling" steels produced by the American inventor William Kelly.<sup>34</sup>

R.F. Mushet made many contributions to the steel industry with his various patents for making special steels. Perhaps his most important legacy is his discovery that certain additions of vanadium and chromium to steel would cause it to self-harden and produce a superior steel for tool making. In the United States, Taylor and White experimented with different alloying elements and also produced famous grades of tool steels. The significance is that these tough tool steels permitted tools to be run at faster speeds, enabling increased machine output.<sup>35</sup>

### 1.5.3.3 Growth of Industrial Chemistry

The third development that had great impact was the budding petrochemical industry. Chemistry had long been involved in the soap, candle, and textile industries. Chemists' endeavors turned to opportunities that the petroleum industry offered, resulting in the creation of a variety of new compounds; many were used in the "new" lubricants needed for growing industrial and manufacturing applications.

### 1.5.3.4 Use of Electricity as a Power Source

The fourth factor was the development of electric power stations that permitted the use of the electric motor as a power source. Before the use of electric motors to drive machines, power was transmitted by a series of belts to permit variable gearing, and then replaced by the clutch. The electric motor permitted connection directly to machine drive shafts. This eliminated some of the machining problems caused by restricted and inconsistently delivered power, which had resulted in problems such as *chatter*. The introduction of steam turbines to drive Edison's dynamos for the generation of electric power in the 1890s<sup>36</sup> was a boon to machine tool designers. Increased sophistication of design and heavier duty capability in machine tools were required in order to produce the machinery needed for the petroleum and electrical power industries, and to make the steam engines and railroad cars for the growing railway transportation ventures. Electric power made the design of more powerful machine tools possible, but the stresses between the tool and the workpiece were increasing in heavy-duty machining operations. The need to mitigate these conditions brought about the natural evolution of sophisticated metalworking fluids.

This period also heralded the beginnings of the investigation into the scientific phenomena operating in the metal removal process and the effectiveness of metalworking fluids in aiding the process. Physicists, chemists, mechanical engineers, and metallurgists all contributed to unravel the mystique of what happens during metalworking and the effect that the metalworking fluid has on the process.

## 1.5.4 EARLY EXPERIMENTATION WITH METALWORKING FLUIDS

It appears that the first known publication on actual cutting fluid applications was in 1868, in *A Treatise on Lathes and Turning* by Northcott. He reported that lathe productivity could be materially increased by using cutting fluids.<sup>37</sup> However, the use of metalworking fluids, especially in

metal removal operations, was widespread in both England and the United States, as evidenced in a report on the Machine Tool Exhibition of 1873 held in Vienna. Mr. J. Anderson, superintendent of the Arsenal at Woolwich, England, wrote that in his opinion the machine tools made in continental Europe were not up to the standards of those in England and America, in that there was a conspicuous absence of any device to supply coolant to the edge of the cutting tool.<sup>38</sup> This observation was confirmed by a drawing of the first universal grinding machine, which was patented by Joseph R. Brown in 1868<sup>39</sup> and appeared in a Brown and Sharpe catalogue of 1875. It included a device for carrying off the water or other fluids used in grinding operations.<sup>40</sup> Obviously, the use of metalworking fluids had become standard machine shop practice.

Curiosity regarding the lubrication effect of metalworking fluids in machining had its beginnings in the publication of the *Proceedings of the Royal Society of London* in 1882. In that publication, Mallock wondered about the mystery of how lubricants appeared to mitigate the effects of friction by going between “the face of the tool and the shaving,” noting that it was impossible to see how the lubricant got there.<sup>41</sup> In that same time frame, evidence for the use of various types of oil in metal cutting operations appeared in Robert H. Thurston’s *Treatise on Friction and Lost Work in Machining and Mill Work*, which described various formulas for metalworking. For example, he stated that the lubricants used in bolt cutting must have the same qualities as those required for “other causes of lubrication.” He cautioned that the choice of lubricant will be determined by the oil giving the smoothest cut and finest finish with “minimum expenditure of power ... whatever the market price.” His advice was that the best lard oil should be commonly used for this purpose, although he agreed with current practice that mineral oil could be used. Thurston also advised in opposition to “earlier opinions, that in using oil on fast running machinery, the best method is to provide a supply as freely as possible, recovering and reapplying after thorough filtration.”<sup>42</sup>

Thurston was an engineer who chaired the Department of Mechanical Engineering at the Stevens Institute of Technology in 1870. His important contributions were in the areas of manufacturing processes, winning him “fame on both sides of the Atlantic.”<sup>43</sup> His well-known lubricant testing machines enabled him to provide advice to machinists. Typically, his studies found that sperm oil was superior to lard oil when cutting steel. In cutting cast iron, he recommended a mixture of plum-bago (black lead oxide) and grease, claiming a lower coefficient of friction.<sup>44</sup>

It was during this period that chemical mixtures with oils came into use as metalworking fluids. Most notable was the advent of the sulfurized cutting oils dating back to 1882. The proper addition of sulfur to mineral oil, mineral–lard oil, and mineral–whale oil mixtures was found to ease the machining of difficult metals by providing better cooling and lubricating qualities and prevented chips from welding onto the cutting tools. Sulfur has the ability to creep into tiny crevices to aid lubrication.<sup>45</sup>

Around this same time, another famous engineer was engaged in an endeavor that forever changed the way machining was carried out and how machine shops were managed. Thurston’s contemporary, Fredrick W. Taylor, was a tool engineer in the employ of the Midvale Steel Company, Philadelphia, Pennsylvania. As foreman of the machine shop, he aspired to discover a method to manage the cutting of metals so that by optimizing machine speeds and work feed rates, production rates could be significantly increased. In 1883, his various experiments in cutting metal proved that directing a constant heavy stream of water at the point of chip removal so increased the cutting speed that the output of the experimental machine rose by 30%–40%.<sup>46</sup> This was a discovery of prime importance when it is considered that it contradicted Mushet, who insisted that as standard practice his “self-hardening” tools must be run “dry.”<sup>47</sup> Taylor’s experiments revealed that the two most important elements of the machining processes were left untouched by experimenters, even those in academia.<sup>48</sup> Those two elements were the effect of cooling the tool with a rapid cooling fluid, and the contour of the tool.

Taylor published his findings in an epochal treatise, *On the Art of Cutting Metal*, in 1907, based on the results of 50,000 tests in cutting 800,000 pounds of metal. He reported that the heavy stream of water, which cooled the cutting tool by flooding at the cutting edge, was saturated with carbonate

of soda to prevent rusting. The cutting fluid was termed *suds*. This practice was incorporated into every machine tool in the new machine shop built by the Midvale Steel Company in 1884. At Taylor's direction, each machine was set in a cast iron pan to collect the suds, which were drained by piping into a central well below the floor. The suds were then pumped up to an overhead tank, from which the coolant was returned to each machine by a network of piping.<sup>49</sup> This was the first central coolant circulation system, the forerunner of those huge 100,000-plus-gallon central coolant systems in use today for supplying cutting fluids to automated machine transfer lines in machining centers.

No secret was made of Taylor's coolant system, and by 1900, the idea of a circulating coolant system was copied in a machine designed by Charles H. Norton. It had a built-in suds tank and a pump capable of circulating 50 gallons of coolant per minute, evidence that Norton appreciated the need to avoid heat deformation at high cutting rates.<sup>50</sup>

### 1.5.5 STATUS OF METALWORKING FLUIDS (1900–1950)

As a result of engineers seeking more productive machining methods in upgrading the design of machine tools, and metallurgists producing stronger and tougher alloy steels, the compounding of metalworking fluids likewise improved. At the turn of the century, the metalworking fluids industry provided machinists with a choice of several metalworking fluids: straight mineral oils, combinations of mineral oils and vegetable oils, animal fats (lard and tallow), marine oils (sperm, whale, and fish), mixes of free sulfur and mineral oil used as cutting oils, and of course suds.

The lubricant manufacturers of this era were well versed in the art of grease making, having learned the value of additives as early as 1869 with E.E. Hendrick's patented Plumboleum, a mixture of lead oxide and mineral oil. Greases, in many cases, were the media of choice used for metal deformation. They were simple compounds, mixtures of metallic soaps, mineral or other oils and fats, and sometimes fibers.<sup>51</sup>

World War I had a significant effect on the course of metalworking fluid development. In the early stages of the European involvement, white oil could no longer be imported from Russia. An American entrepreneur, Henry Sonneborn, who had made petroleum jelly and white oil for the pharmaceutical industry since 1903, found his white mineral oil and related products in great demand by lubricant manufacturers.<sup>52</sup> Chemists entered the endeavor by using a chemical process, the acidification of neutral oil with sulfuric acid, which resulted in a reaction product, a mixture of white oil and petroleum sulfonate. The white oil was extracted with alcohol. The sulfonate was discarded until it was discovered to be most useful as a lubricating oil additive and also in compounding metalworking fluids. Sulfonates were eventually found to combine with fatty oils and free fatty acids to make emulsions.<sup>53</sup>

#### 1.5.5.1 Development of Compounded Cutting Oils

As tougher alloy steels became more common, and as machine tool and cutting tool speeds increased, the stresses incurred in the machining process tended to overwork the cutting oils. These were mostly combinations of mineral oils and lard oil, or mixtures of free sulfur and mineral oil. Overworking caused a chemical breakdown resulting in objectionable odors, rancidity, and very often dermatitis.

The disadvantages of those cutting oils had to be addressed. In 1918, no doubt spurred on by the demands of the munitions industries and the need for greater precision in machining, serious research into better compounding of sulfurized cutting oils began and continued into the late 1920s. The problems to overcome were to extend the limits of sulfur combined with mineral oil by effecting a means of chemically reacting sulfur with the hydrocarbon molecules. This inhibited the natural corrosiveness of sulfur, yet gained the maximum benefit of it for the machining process. In 1924, a special sulfo-chlorinated oil was patented by one of the oldest lubricant compounding

companies in the United States and marketed as Thread-Kut 99. It is still used today for such heavy-duty machining operations as thread cutting and broaching on steels.<sup>54</sup>

However, these chemically compounded oils did not solve all cutting difficulties. The new, highly sulfo-chlorinated cutting oils could not be used for machining brass or copper since sulfur additives stained those metals black and contributed to eventual corrosion.<sup>55</sup>

### 1.5.5.2 Development of Soluble Oils

The worth of Taylor's experience was not lost on the engineering and manufacturing community. His demonstration of the profound effect that an aqueous chemical fluid had on machine productivity began the search for water/oil/chemical-based formulas for metalworking fluids. W.H. Oldacre has written that, although "water-mixed oil" emulsions were used extensively in the first quarter of the twentieth century, and the wide range of formulations made a very important contribution to machine shop practice, it is not clear when the first crude emulsions were made by mixing suds with fatty lubricants. History has neglected the commercial development of soluble oils.<sup>56</sup>

Around 1905, when chemists began to look at colloidal systems, the scientific basics of metalworking fluid formulation began to unfold. Industrial chemists focused their attention on emulsions, colloidal systems in which both the dispersed and continuous phases are liquids. Two types of emulsions were recognized: a dispersion of oil or hydrocarbon in aqueous material, such as milk and mayonnaise, and dispersions of water in oil such as butter, margarine, and oil field emulsions. Theories of emulsification began with the surface tension theory, the adsorption film theory, the hydration theory, and the orientation theory put forth by Harkins and Langmuir. These theories explained the behavior of emulsifying agents, which eventually found a direct application in the formulation of cutting fluids.

It has been reported that an English chemist, H.W. Hutton, discovered a way to emulsify oil in water in 1915. What it comprised and how it was made is not described.<sup>57</sup> However, in the United States in 1915, an early brochure ("Technical Bulletin 16," still available from the Sun Refining Company, Tulsa, Oklahoma) by one of the oldest oil companies claimed the innovation of the first "all petroleum based (naphthenic) soluble oil." This was first marketed under the name of Sun Seco during World War I.

The growing body of knowledge on colloid and surfactant chemistry led to the compounding of various soluble oils using natural fatty oils. H.W. Hutton was granted a patent for the process of producing water-soluble oils by compounding sulfonated and washed castor oil with any sulfonated unsaponified fatty oil (other than castor oil), and then saponifying the sulfonated oils with caustic alkali.<sup>58</sup>

After World War I, new developments in lubrication science through the work of Hardy and Doubleday (1919–1933) elucidated the mechanism of boundary lubrication.<sup>59</sup> The petrochemical industry began to flourish, while applications for new synthetic chemicals, such as detergents and surfactants, found many commercial and industrial uses. The automobile industry recovered. The effort to speed up the mass production of cars required stronger machine tools capable of faster cutting speeds. Oil–water emulsions were the preferred fluids, except in heavy-duty machining operations such as broaching, gear hobbing, and the thread cutting of tough alloy steels, where chemically compounded oils were used.

The need for stable emulsions in the food, cosmetics, and soap making industries, as well as by the metalworking fluid manufacturers, maintained high interest in oil–water emulsions. The research of B.R. Harris, expanding on the orientation theory of emulsions, focused on the synthesis of many new compounds, relating their chemical structure to various types of surface modifying activity. Reporting in *Oil and Soap* magazine, Harris established that all fatty interface modifiers have two essential components: a hydrophilic part that makes the compound water soluble and a lipophilic part that makes the compound fat soluble. These must be in balance to effect a good emulsion.<sup>60</sup> As research in this area continued, many emulsifying agents were developed for the previously mentioned industries. Some, the amine soaps, wetting agents, and other special-function

molecules, were compounded with mineral and/or vegetable oils by metalworking fluid compounders to effect stable soluble oils.<sup>61</sup>

### 1.5.5.3 Influence of World War II

With the growth of the aircraft industry, exotic alloys of steel and nonferrous metals were introduced, creating the need for even more powerful machine tools having greater precision capability. Better metalworking fluids to effectively machine these new tough metals were also needed. The circumstances of World War II, which demanded aircraft, tanks, vehicles, and other war equipment, began a production race of unknown precedent. Factories ran 24 hours daily, never closing in the race to produce war goods. The effort centered on new machine tool design to shape the new materials and to make production parts as fast as possible. The cover of the February 24, 1941, edition of *Newsweek* magazine featured a huge milling machine, carrying the title “The Heart of America’s Defense: Machine Tools.” In fact, metalworking fluids along with machine tools are at the heart of the cutting process. The demand for more effective war production translated into faster machining speeds. Higher feed rates using the available fluids led to problems such as poor finishes, excessive tool wear, and part distortion. The need to satisfy the war production demand mandated inquiry into the mechanics of the machining process in both Europe and the United States.

### 1.5.5.4 Mechanisms of Cutting Fluid Action

In 1938 in Germany, Schallbroch, Schaumann, and Wallichs tested machinability by measuring cutting temperature and tool wear, and in so doing derived an empirical relationship between tool life and cutting tool temperature.<sup>62</sup> In the United States in about the same period, H. Ernst, M.E. Merchant, and M.C. Shaw studied the mechanics of the cutting process. Ernst studied the physics of metal cutting and determined that a rough and torn surface is caused by chip particles adhering to the tool causing a built-up edge (BUE) on the nose of the cutting tool due to high chip friction. The application of a cutting fluid lowered the chip friction and reduced or eliminated the BUE.<sup>63</sup> This confirmed Rowe’s opinion that the BUE was the most important consideration to be addressed in the machining process.<sup>64</sup> Numerous studies by many engineers and scientists were made, but the researchers who made the most important discoveries affecting the course of metalworking fluid development were employed by one of the largest machine tool builders in the United States.

Ernst and Merchant, seeking to quantify the frictional forces operating in metal cutting, developed an equation for calculating static shear strength values.<sup>65</sup> Merchant, in another study, was able to measure temperatures at the chip–tool interface. He found that in this area, heat evolves from two sources: the energy used up in deforming the metal and the energy used up in overcoming friction between the chip and the tool. Roughly two-thirds of the power required to drive the cutting tool is consumed by deforming the metal, and the remaining one-third is consumed in overcoming chip friction. Merchant found that the right type of cutting fluid could greatly reduce the frictional resistance in both metal deformation and in chip formation, as well as reduce the heat produced in overcoming friction.<sup>66</sup>

Ernst and Merchant began a 3-year study to scientifically quantify the friction between the cutting tool and the chip it produced. They found temperatures at the tool–chip interface ranging between 1000°F and 2000°F (530°C and 1093°C) and the pressure at the point was frequently higher than 200,000 psi (1,380,000 kPa).<sup>67</sup> Bisshopp, Lype, and Raynor also investigated the role of the cutting fluid in machining experiments to determine whether or not a continuous film existed in the chip–tool interface. They admitted that in some experiments, the cutting fluid did appear to penetrate, as indicated by an examination of the tool and the workpiece under ultraviolet light. They concluded that a continuous film, as required for hydrodynamic lubrication, could not exist in the case where a continuous chip was formed. Neither was it possible for fluid to reach the areas where there was chip–tool contact in the irregularity of the surfaces.<sup>68</sup> Other researchers, A.O. Schmidt, W.W. Gilbert, and O.W. Boston, investigated radial rake angles in face milling and the coefficient of friction with drilling torque and thrust for different cutting fluids.<sup>69</sup> Schmidt and

Sirotkin investigated the effects of cutting fluids when milling at high cutting speeds. Depending on which of the various cutting fluids were used, tool life increased approximately 35%–150%.<sup>70</sup>

Ernst and Merchant studied further the relationship of friction, chip formation, and high-quality machined surfaces. Their research belied the conclusions of Bisshopp, Lype, and Raynor.<sup>68</sup> They found that cutting fluid present in the capillary spaces between the tool and the workpiece was able to lower friction by chemical action.<sup>71</sup> Shaw continued this study of the chemical and physical reactions occurring in the cutting fluid and found that even the fluid's vapors have constituents that are highly reactive with the newly formed chip surfaces. The high temperatures and pressures at the contact point of the tool and chip effect a chemical reaction between the fluid and the tool–chip interface, resulting in the deposition of a solid film on the two surfaces that becomes the friction reducing agent.<sup>72,73</sup>

Using machine tool cutting tests on iron, copper, and aluminum with pure cutting fluids, Merchant demonstrated that this reaction product, which “plated out” as a chemical film of low shear strength, was indeed the friction reducer at the tool–chip interface. He stated that materials such as free fatty acids react with metals to form metallic soaps, and that the sulfurized and sulfo–chlorinated additives in turn form the corresponding sulfides and chlorides acting as the agents that reduce friction. However, he quickly cautioned that as cutting speeds increase, temperature increases rapidly, and good cooling ability from the fluid is essential. At speeds of over 50 ft/min (254 mm/s), the superior cutting fluid must have the dual ability to provide cooling as well as friction reduction capacity.<sup>74</sup>

Having learned which chemical additives are effective as friction reducers, Ernst, Merchant, and Shaw theorized that if they could combine these chemicals with water in the form of a stable chemical emulsion, a new cutting fluid having both friction reducing and cooling attributes could be created. In 1945, as a result of this research, their company compounded a new type of cutting fluid.<sup>75</sup> The new product, described as a water-soluble cutting emulsion, a semisynthetic with the name CIMCOOL®, appeared as a news item in a technical journal in October 1945.<sup>76</sup> Two years later, the first semisynthetic metalworking fluid was introduced by this same company at the 1947 National Machine Tool Builders Show. It was a preformed emulsion very similar to a soluble oil but with better rust control and chip washing action.<sup>77</sup> This research was one of the most important developments in metalworking fluid formulation, in that it provided the impetus for a whole new class of metalworking fluids, facilitating the new high-speed machining and metal deformation processes developed in the next quarter-century.

#### 1.5.5.5 Metalworking Fluids and the Deformation Process

During the same period of investigation into cutting fluid effects on the metal removal process, many papers appeared in technical journals on the ameliorating effects of lubricants and *coolants*, as the aqueous-based fluid came to be termed. In the next decade, much research appeared in the technical literature on the theories of metalforming and how the lubricants used affected the metal deformation processes of extrusion, rolling, stamping, forging, drawing, and spinning. Notable among them is the often-quoted work by Bowden and Tabor on the friction and lubrication of solids,<sup>78</sup> Nadai's theory of the flow and fracture of solids,<sup>79</sup> Bastian's works on metalworking lubricants discussing their theoretical and practical aspects,<sup>80</sup> theories of plasticity by Hill in 1956<sup>81</sup> and by Hoffman and Sacks,<sup>82</sup> followed by Leug and Treptow's discussion of lubricant carriers used in the drawing of steel wire.<sup>83</sup> Also notable are the investigations of Billigman and Fichtl on the properties and performance of the new cold rolling emulsions,<sup>84</sup> and Schey's investigations of the lubrication process in the cold rolling of aluminum and aluminum alloys.<sup>85</sup>

Metalworking deformation processes involve tremendous pressures on the metal being worked. Consequently, very high temperatures are produced, demanding a medium to effect friction reduction and cooling. If these stresses are not mitigated, there is the imminent danger of wear and metal pickup on the dies, producing scarred work surface finishes.<sup>86</sup> To prevent these maleffects of metalforming, a suitable material must be used to lubricate, cool, and cushion both the die and the workpiece. In general, metal deformation processes rely on the load carrying capacity and the

frictional behavior of metalworking lubricants as their most important property. In some cases, however, friction reduction is critical, as in rolling operations. Insufficient friction would permit the metal to slide edgewise in the mill and cause the rolls to slip on the entering edge of the sheet or strip. Lack of friction also causes a problem in forging, a condition known as *flash*, which prevents sufficient metal from filling the die cavities.<sup>87</sup>

## 1.6 METALWORKING FLUIDS TODAY

At mid-century, metalworking fluids had acquired sufficient sophistication and proved to be the necessary adjunct in high-speed machining and in the machining of difficult material: the exotic steels and specially alloyed nonferrous metals. They began to be regarded as the “corrector” of many machining problems and sometimes, by the uninitiated or inexperienced, were expected to be a cure-all for most machining problems. In the next decade, many cutting fluid companies sprang into existence offering a multitude of metalworking formulations to ameliorate machining problems and increase rates of production. Listings of metalworking fluids are to be found in a great number of publications of technical papers and handbook publications of various societies that cater to the lubrication engineering, tool making, and metallurgical communities.

Considering the many processes and the myriad of products available, there was, and is, confusion and controversy as to the best choice of fluid in any given situation. In the 1960s, the literature published by various technical organizations on the subject of how and what to use in metalworking processes was profuse. It was recognized by the metalworking community that direction was desirable, but there seems to be an isolation of those involved in the metalworking process from those involved in metalworking lubrication. As Schey has pointed out, the province of the metalworking process has traditionally been within the sphere of mechanical engineers and metallurgists, while the area of metalworking lubrication was within the expertise of chemists, physicists, and manufacturing process engineers. The National Academy of Science, observing this division, realized the need for communication among these specialists to integrate current knowledge and further the expansion of metalworking fluid technology and metalworking processes. They directed their Materials Advisory Board to institute the Metalworking Processes and Equipment Program, a joint effort of the army, navy, air force, and NASA. One of the outcomes of this program was a comprehensive monograph containing the interdisciplinary knowledge of metalworking processes and metalworking lubricants to serve as both a text and a reference book.<sup>88</sup>

This brief history of the evolution of metalworking fluids shows that the dynamics of metalworking fluid technology are dependent on the dynamics of metalworking processes as created by the parameters of machine tool design. These dynamics are mutually dependent parts of the total process and can only be investigated jointly. The body of knowledge evolving from metalworking fluid technology developed by these “cross-culture”<sup>89</sup> engineers and scientists contributed significantly to the growing body of science and technology in the area of friction, lubrication, and wear. In the late 1960s, this technology blossomed into a new science named *tribology*. A “veritable explosion of information” has followed since 1970.<sup>90</sup>

Today’s metalworking fluid compounders find themselves having to harken to and abide by the edicts of new government regulations regarding the impact of formulation chemicals on the environment, as well as machine operator health and safety. Inattention to these edicts can well lead to cases of product liability with dire ramifications. It has been pointed out that “societal concerns about jobs often clash with society’s demand for a risk-free environment” in which to live.<sup>91</sup> Regulatory issues, as well as health and safety aspects, will be covered thoroughly in later chapters.

During the mid-1980s, the automotive industries realized that metalworking fluids, as an integral part of the metalworking process, were fully as important as the metals used in the manufacture of assembly parts. Industrial management wanted guarantees that the metalworking fluids would be maintained in such a condition as to enable the production of certain quantities of parts without interruption. Negotiations in this area produced a new form of metalworking fluid management<sup>92</sup>

in which the supplier, working with a committee of factory personnel, supplied the fluids and technical expertise and guaranteed the fluid performance in terms of the number of parts produced. More recently, there has been a trend toward “independent” chemical managers that are not lubricant manufacturers. This *tier-one* manager buys the fluid from the *tier-two* fluid supplier, and then maintains the fluid on-site within the end user’s plant. In 2005, the Society of Tribologists and Lubrication Engineers (STLE) began offering courses and certification for in-plant fluid managers.

New methods of metalworking are constantly being developed. For example, water jets and lasers<sup>93</sup> are being used to cut both metal and nonmetal parts. Some machining is being carried out either using dry or near-dry methods.<sup>94</sup> Just as in the days of R.F. Mushet, dry machining is often touted by tooling suppliers.<sup>95</sup> Recent work has shown that the use of metalworking fluid will greatly reduce the amount of hexavalent chrome (a carcinogen) generated by dry grinding of stainless steel, and keep hexavalent chrome from contaminating the community outside the manufacturing facility.<sup>96</sup> Cooled, compressed air has been used to cool the metal-cutting process and move the chips out of the way, while vacuum systems remove the chips to a collection bin. In other cases, a small amount of vegetable oil is introduced into the air stream to help lubricate without using enough fluid to require collection or recirculation.<sup>97</sup> However, the demand for high-speed production machining will continue, and metalworking fluids continue to be the “enabler.”<sup>98,99</sup>

## REFERENCES

1. Lubricants industry factbook 2014: A supplement to *Lubes 'n' Greases Magazine*, p. 14, 2014.
2. Phadke, M., Analysis: The global metalworking fluids market, *Tribol. Lubr. Technol.*, 70(3), 38–43, 2014.
3. Wills, J. G., *Lubrication Fundamentals*, Marcel Dekker, New York, pp. 1–2, 1980.
4. Schey, J. A., *Metal Deformation Processes: Friction and Lubrication*, Marcel Dekker, New York, p. 1, 1970.
5. Bastian, E. L. H., Modern developments in fluids and metal forming operations, *Lubr. Eng.*, 25(7), 278, 1969.
6. Dowson, D., *History of Tribology*, Longmans Green, New York, p. 253, 1979.
7. Singer, C., et al., *A History of Technology, Vol. III*, Oxford University Press, London, p. 668, 1957.
8. Singer, C., et al., *A History of Technology, Vol. III*, Oxford University Press, London, p. 663, 1957.
9. Dowson, C., *History of Tribology*, Longmans Green, New York, p. 126, 1979.
10. Schey, J. A., *Metal Deformation Processes: Friction and Lubrication*, Marcel Dekker, New York, pp. 1–2, 1970.
11. Dowson, D., *History of Tribology*, Longmans Green, New York, pp. 177–178, 1979.
12. Dowson, D., *History of Tribology*, Longmans Green, New York, p. 154, 1979.
13. Bastian, E. L. H., *Metal Working Lubricants*, McGraw-Hill, New York, p. 3, 1951.
14. Singer, C., et al., *A History of Technology, Vol. III*, Oxford University Press, London, p. 669, 1957.
15. Lewis, K. B., *Wire Ind.*, 1, 4–8, 1936.
16. Lewis, K. B., *Wire Ind.*, 2, 49–55, 1936.
17. Schey, J. A., *Metal Deformation Processes: Friction and Lubrication*, Marcel Dekker, New York, p. 5, 1970.
18. Rolt, L. T. C., *A Short History of Machine Tools*, MIT Press, Cambridge, MA, p. 11, 1965.
19. Woodbury, R. S., *Studies in the History of Machine Tools*, MIT Press, Cambridge, MA, p. 1, 1972.
20. Dowson, D., *History of Tribology*, Longmans Green, New York, pp. 21–23, 1979.
21. Woodbury, R. S., *History of the Lathe to 1850*, MIT Press, Cambridge, MA, p. 23, 1961.
22. Landels, J. G., *Engineering in the Ancient Worlds*, University of California Press, Berkeley, CA, pp. 77, 199–215, 1978.
23. Woodbury, R. S., *History of the Grinding Machine*, MIT Press, Cambridge, MA, p. 13, 1959.
24. Woodbury, R. S., *History of the Grinding Machine*, MIT Press, Cambridge, MA, p. 23, 1959.
25. Woodbury, R. S., *History of the Grinding Machine*, MIT Press, Cambridge, MA, p. 21, 1959.
26. Gilbert, K. B., et al., *The Industrial Revolution 1750–1850, History of Technology, Vol. IV*, Oxford University Press, London, p. 417, 1958.
27. Rolt, L. T. C., *A Short History of Machine Tools*, MIT Press, Cambridge, MA, p. 138, 1965.

28. Handlin, O., *Eli Whitney and the Birth of Modern Technology*, Little, Brown, Boston, MA, pp. 119–143, 1956.
29. Handlin, O., *Eli Whitney and the Birth of Modern Technology*, Little, Brown, Boston, MA, p. 170, 1956.
30. Woodbury, R. S., *History of the Grinding Machine*, MIT Press, Cambridge, MA, p. 41, 1959.
31. Naysmyth, J., *James Naysmyth: An Autobiography*, Stiles, S., Ed., Harper, London, p. 437, 1883.
32. Dowson, D., *History of Tribology*, Longmans Green, New York, pp. 286–287, 1979.
33. Million Dollar Directory, *America's Leading Public and Private Companies*, Dunn and Bradstreet, Parsippany, NJ, 1991.
34. Osborn, F. M., *The Story of the Mushets*, Thomas Nelson, London, pp. 38–52, 1952.
35. Osborn, F. M., *The Story of the Mushets*, Thomas Nelson, London, pp. 89–95, 1952.
36. Morris, R. B., Ed., *Encyclopedia of American History*, Harper and Rowe, New York, pp. 562–565, 1965.
37. Northcott, W. H., *A Treatise on Lathes and Turning*, Longmans Green, London, 1868.
38. Steed, W. H., *History of Machine Tools 1700–1910*, Oxford University Press, London, p. 91, 1969.
39. Woodbury, R. S., *History of the Grinding Machine*, MIT Press, Cambridge, MA, p. 167, 1959.
40. Woodbury, R. S., *History of the Grinding Machine*, MIT Press, Cambridge, MA, p. 65, 1959.
41. Mallock, A., Action of cutting tools, *Proceedings of the Royal Society of London*, 33, 127, 1881.
42. Thurston, R. H., *A Treatise on Friction and Lost Work in Machining and Millwork*, Wiley, New York, p. 141, 1885.
43. Dowson, D., *History of Tribology*, Longmans Green, New York, p. 551, 1979.
44. Thurston, R. H., *A Treatise on Friction and Lost Work in Machining and Millwork*, Wiley, New York, p. 284, 1885.
45. *Lubrication*, The Texas Oil Company, New York, Vol. 39, p. 10, 1944.
46. Taylor, F. W., *On the Art of Cutting Metals*, Society of Mechanical Engineers, New York, pp. 138–143, 1907.
47. Rolt, L. T. C., *A Short History of Machine Tools*, MIT Press, Cambridge, MA, p. 198, 1965.
48. Taylor, F. W., *On the Art of Cutting Metals*, Society of Mechanical Engineers, New York, pp. 14, 137–138, 1907.
49. Taylor, F. W., *On the Art of Cutting Metals*, Society of Mechanical Engineers, New York, p. 9, 1907.
50. Rolt, L. T. C., *A Short History of Machine Tools*, MIT Press, Cambridge, MA, p. 213, 1965.
51. *Lubrication*, The Texas Oil Company, New York, Vol. 39, p. 73, 1944.
52. *The Oil Daily*, August 6, pp. B7–B8, 1960.
53. Hutton, H. W., Improvements in or relating to the acid refining of mineral oil, British Patent No. 13,888/20, 1920.
54. Oldacre, W. H., Cutting fluid and process of making the same, U.S. Patent No. 1,604,068, 1923.
55. *Lubrication*, The Texas Oil Company, New York, Vol. 39, pp. 9–16, 1948.
56. Oldacre, W. H., Water mixtures as grinding and cutting fluids, *Lubr. Eng.*, 1(8), 162, 1948.
57. Kelly, R., *Carbide Tool J.*, 117(3), 28, 1985.
58. Hutton, H. W., Process of producing water-soluble oil, British Patent No. 13,999, 1923.
59. Dowson, D., *History of Tribology*, Longmans Green, New York, p. 351, 1979.
60. Harris, B. R., Epstein, S., and Cahn, R., *J. Am. Oil Chem. Soc.*, 18(9), 179–182, 1941.
61. *Emulsions*, 7th edn., Carbide and Carbon Chemicals, New York, pp. 28–39, 1946.
62. Schallbock, H., Schaumann, H., and Wallichs, R., Testing for machinability by measuring cutting temperature and tool wear, *Vortrage der Hauptversammlung der Deutsche Gesellschaft für Metalkunde*, V.D.I. Verlag, Dusseldorf, Germany, pp. 34–38, 1938.
63. Ernst, H., *Physics of Metal Cutting, Machining of Metals*, American Society of Metals, Cleveland, OH, pp. 1–34, 1938.
64. Rowe, G. W., *Introduction of Principles of Metalworking*, St Martin's Press, New York, pp. 265–269, 1965.
65. Ernst, H., and Merchant, M. E., *Surface Friction of Clean Metals: Proceedings of Massachusetts Institute of Technology Summer Conference on Friction and Surface Finish*, pp. 76–101, 1940.
66. Merchant, M. E., *J. Appl. Phys.*, 16, 267–275, 1945.
67. Kelly, R., *Carbide Tool J.*, 17(3), 26, 1985.
68. Bisschopp, K. E., Lype, E. F., and Raynor, S., The role of cutting fluid as a lubricant, *Lubr. Eng.*, 6(2), 70–74, 1950.
69. Schmidt, A. O., Gilbert, W. W., and Boston, O. W., *Trans. ASME*, 164(7), 703–709, 1942.
70. Schmidt, A. O., and Sirotkin, G. B. V., Effects of cutting fluids and power requirements in metal cutting operations, *Lubr. Eng.*, 4(12), 261–265, 1948.

71. Ernst, H., and Merchant, M. E., *Surface Treatment of Metals*, American Society of Metals, Cleveland, OH, pp. 299–337, 1948.
72. Shaw, M. C., *Met. Prog.*, 42(7), 85–89, 1942.
73. Shaw, M. C., *J. Appl. Mech.*, 113(3), 37–44, 1948.
74. Merchant, M. E., Fundamentals of cutting fluid action, *Lubr. Eng.*, 6(8), 163–167, 1950.
75. Schwartz, J., *Cincinnati Milacron 1884–1984: Finding Better Ways*, Hennegan, Florence, KY, p. 88, 1984.
76. Jennings, B. H., New products and equipment: Water soluble emulsion, *Lubr. Eng.*, 1, 79, 1945.
77. Kelly, R., *Carbide Tool J.*, 17(3), 29, 1985.
78. Bowden, F. P., and Tabor, F., *Friction and Lubrication of Solids*, Clarendon Press, Oxford, 1950.
79. Nadai, A., *Theory of Flow and Fracture of Solids*, McGraw-Hill, New York, 1950.
80. Bastian, E. L. H., *Metalworking Lubricants*, McGraw-Hill, New York, 1951.
81. Hill, R., *The Mathematical Theory of Plasticity*, Oxford University Press, London, 1956.
82. Hoffman, O., and Sachs, G., *Theory of Plasticity*, McGraw-Hill, New York, 1957.
83. Leug, W., and Treptow, K. H., *Stahl u. Eisen*, 76, 1107–1116, 1956.
84. Billigman, J., and Fichtl, W., *Stahl u. Eisen*, 78, 344–357, 1958.
85. Schey, J., Lubricants for cold rolling aluminum, *J. Inst. Met.*, 89, 1–6, 1960.
86. Rowe, G. W., Friction and metal transfer, *Wear*, 7, 204–216, 1964.
87. Sargent, L. B., A general view of metalworking lubrication, *Lubr. Eng.*, 21(7), 286, 1965.
88. Schey, J. A., *Metal Deformation Processes: Friction and Lubrication*, Marcel Dekker, New York, 1970.
89. Ludema, K. C., Engineering progress and cultural problems in tribology, *Lubr. Eng.*, 44(6), 501–509, 1988.
90. Schey, J., *Tribology in Metalworking*, American Society for Metals, Metals Park, OH, p. V, 1983.
91. Nachtman, E., and Kalpakjian, S., *Lubricants and Lubrication in Metalworking Operations*, Marcel Dekker, New York, p. 215, 1985.
92. Sullivan, T., Older wiser CMS providers take stock, *Lubes 'n' Greases*, 24–29, June 2003.
93. Gotz, D., Waterjet gives steel ribbon maker a productivity lift, *Mod. Appl. News*, 78–81, 2000.
94. Canter, N., The possibilities and limitations of dry machining, *Tribol. Lubr. Technol.*, 30–35, November 2003.
95. Anon, Dry steel turning pays off with lower part costs, longer tool life, *Mod. Appl. News*, 44–47, July 2002.
96. Burke, J. and Cross, A., Toxic metal emissions from dry machining operations, paper presented at STLE Annual Meeting in Atlanta, May 2017.
97. Anon, Making the case for near-dry machining, *Mod. Appl. News*, 54–55, April 2001.
98. Krueger, M., et al., New technology in metalworking fluids and grinding wheels achieves 130-fold improvement in grinding performance, *Abrasives Mag.*, 8–15, October/November 2000.
99. Ezugwu, E., et al., The effect of argon enriched environment in high speed machining of titanium alloy, *Tribol. Trans.*, 48, 18–23, 2005.